

# OPERATING INSTRUCTIONS

## BEMA 1000



### Important:

Before application, carefully read the usage instructions for the unit and the chemicals!  
Observe safety instructions!  
For questions regarding the chemicals, consult the manufacturer!  
Application is to be performed only by a competent user.

### Remarks about usage of the unit:

**Settings:** Use herbicides for testing the spray action and calibration of the flow rate.

**Usage:** Position the spray hood/atomiser directly above the ground –  
if the spray hood is held too high, the danger of spray driftage exists.



**Cleaning:** Do not clean the unit with a high-pressure spray or an intense water jet spray.

**Storage:** Store the unit at an angle of between ca. 45° (= work position) and  
0° (= horizontal) to the floor (see picture).

**Keep the applicator and pesticides out of the reach of children.**

Work position

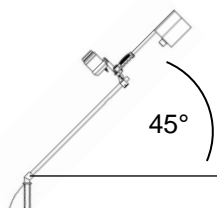

Storage: correct

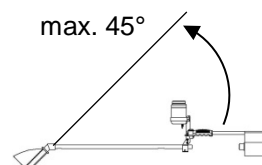

**Noise emission from the unit equates to less than 70 dB(A).**

Manufacturer:

**Mantis ULV-Sprühgeräte GmbH**

Germany 21502 Geesthacht, Vierlander Str. 11 a

Telephone +49(0)4152-8459-0, FAX +49(0)4152-8459-11

Web: [www.mantis-ulv.eu](http://www.mantis-ulv.eu) Email: [mantis@mantis-ulv.eu](mailto:mantis@mantis-ulv.eu)

# BEMA 1000

**Before application, carefully read the usage instructions for the applicator and chemical.**

**Observe safety instructions.**

**For questions regarding chemical, consult the manufacturer!**

**Observe the requirements and regional regulations for the use of chemicals.**

**Application is to be performed only by a competent user.**

Noise emission from the unit equates to less than 70 dB (A).

## Protective measures

Observe remarks in the usage instructions for the chemical regarding the safety of the user; wear recommended body protection. Wear protective gloves when filling the product.

Do not eat, smoke or drink while working with chemicals. Avoid chemical spillage without fail. After completion of the work, thoroughly clean hands and face.

Thoroughly clean and dry the unit immediately following its usage. Never use the mouth to blow out nozzles or other small parts!



**Keep chemicals and applicators away from children.**

## Assembly and preparation for the first application

Assembly of this unit is described on page 2.

Before the first application of the unit, allow the battery to charge for at least 16 hours. First plug the applicator plug into the loading socket, then plug the charging device into the 230 V power outlet. After ca. 16 hours charging time, the battery has reached its full voltage capacity. When the charging process is complete, first unplug the charging device from the 230 V power outlet, then unplug the unit plug from the charger socket.

The spray width should be subsequently checked - ideally with a piece of cardboard laid out on the ground - and the flow rate adjusted (see below for specifics).

**Applicator function:** The rotating atomiser is driven by means of a rechargeable battery. Metering takes place by means of a metering valve. Droplets are formed by the centrifugal force of the rotating atomiser. The residual chemical in the tank, not able to be applied, is approximately 10 ml. This residual fluid can be refilled back into the original chemical container.

**Checking applicator function:** Chemicals can flow at differing rates, more quickly or slowly, due to temperature variations. For this reason, the flow rate depicted in the metering table must be checked and corrected as necessary. Always use herbicides for testing the spray process and for calibrating the flow rate. Check the rotating atomiser for cleanliness and free turning movement on a daily basis. Check the application volume from time to time throughout the season.

**Attention!** Before lifting or tilting the atomiser, it is essential that the stop valve is closed and the atomiser motor is switched off.

## Setting and verification

### Flow rate

- Place an underlay (e.g. cardboard or paper) on the ground.
- Pull out the phone jack from the powerpack (A).
- Fill the chemical tank with chemical.
- Set down the applicator as pictured below.
- Remove the hose from below the flow rate controller. (D)
- Place the measuring cylinder beneath the flow rate controller. (D)
- First set metering valve to maximum. (C)
- Actuate switch (E) first and afterwards valve unit (B)
- When the chemical reaches the metering valve (identifiable in the flow rate controller), the desired setting is adjusted on the valve. (C)
- Collect the herbicide for 60 sec. in the measuring cylinder.
- If desired quantity is not reached, readjust metering valve and calibrate again.
- Afterwards reattach stereo jack and hose.

### Working width

- The atomiser of the BEMA has a working width of 80cm.

When the desired volume is obtained the application process can begin.

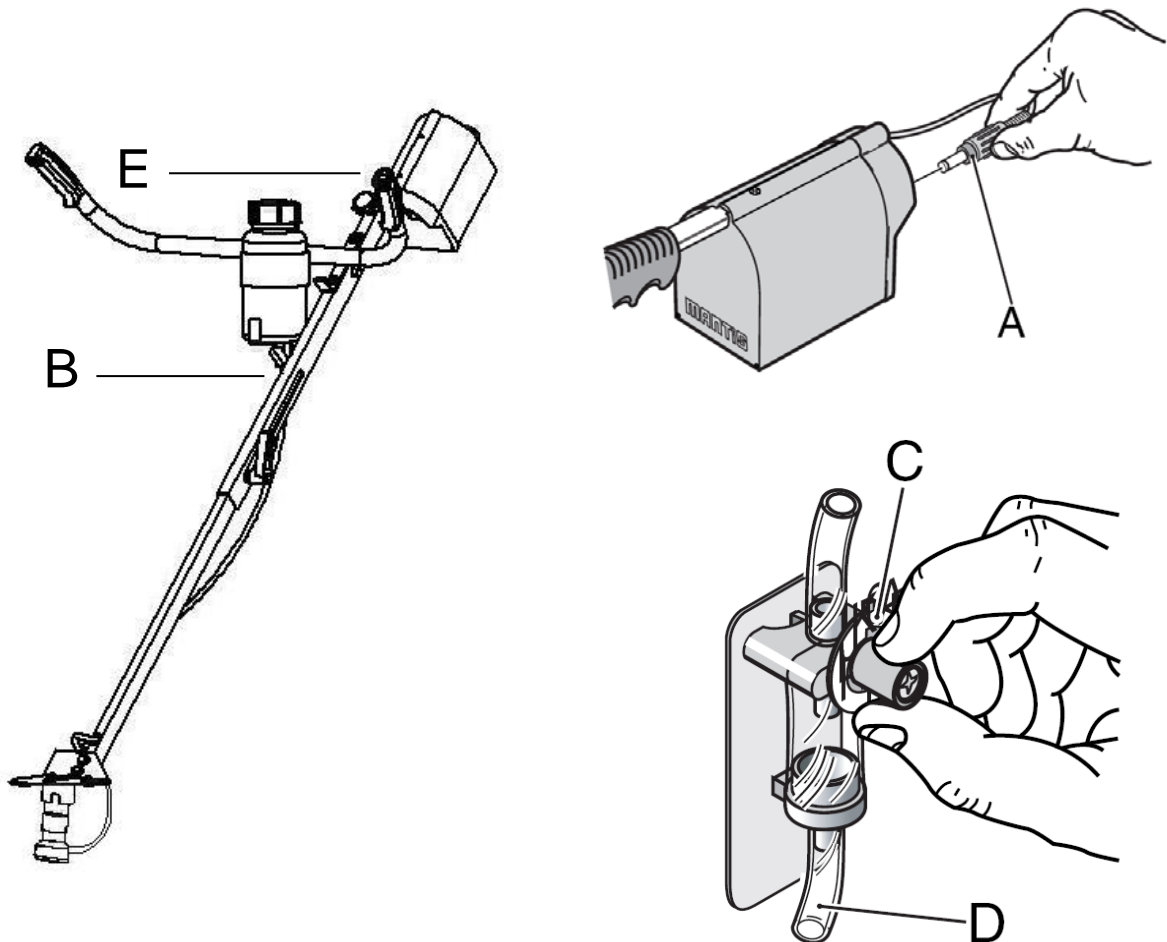

## Cleaning

Do not clean the applicator with a high-pressure spray or with an intense water jet spray.

**Cleaning during the season:** During short breaks in the work day (a few hours), the chemical can remain in the system as long as the metering valve is closed. After completion of work task: before cleaning, return the chemical into its original container. Set the metering valve to maximum (water cock symbol). Fill the chemical tank half way with cleaning agent, actuate the button switch and allow the atomiser to run for 3 minutes over a collector tank.



### Charging the applicator and care of the accumulator

The applicator is fitted with an automatic charging device. Trickle charging is possible.

In order to charge a completely empty battery back up to full capacity, ca. 16 hours charging time is empty, it should be immediately recharged. Never leave a battery discharged for long periods.

Battery charging	Minimum charging time	Time interval
Fully discharged	16 hrs.	immediately
Short-term usage	6 hrs.	immediately
Storage without usage	( 2 hrs. 1 x per month)	<b>or permanent charge</b>

The applicator can be used for ca. 16 hours with a fully charged battery.

## Fault remedy

Fault	Cause	Remedy
<b>Atomiser disc not turning</b>	Atomiser contaminated Battery empty Fuse blown	Thoroughly clean atomiser, remove plant parts if needed Charge battery Replace fuse on powerpack (Replacement fuses are located in the powerpack housing)
	No electrical contact Battery defective Atomiser motor defective	Check cable or connector contact Install new battery Install new motor Connect the brown cable to Plus (+).
<b>Atomiser drips</b>	Metering valve incorrectly set Atomiser disc defective / contaminated Atomiser spray discharge contaminated	Check setting, see table Replace / clean disc Clean
<b>Atomiser foams</b>	Residual water in system	Completely empty container, hose, segmental atomiser.
<b>Chemical not flowing evenly</b>	Metering valve clogged	Set scale to maximum  . Take off hose of upper side of metering valve and blow through with compressed air or use cleaning syringe (accessory art.-no. 100348).
<b>Air in hose line</b>	Hose connection / Filter leaking	Slightly shorten the hose and set onto a hose nipple. Re-tighten the screw on the filter.

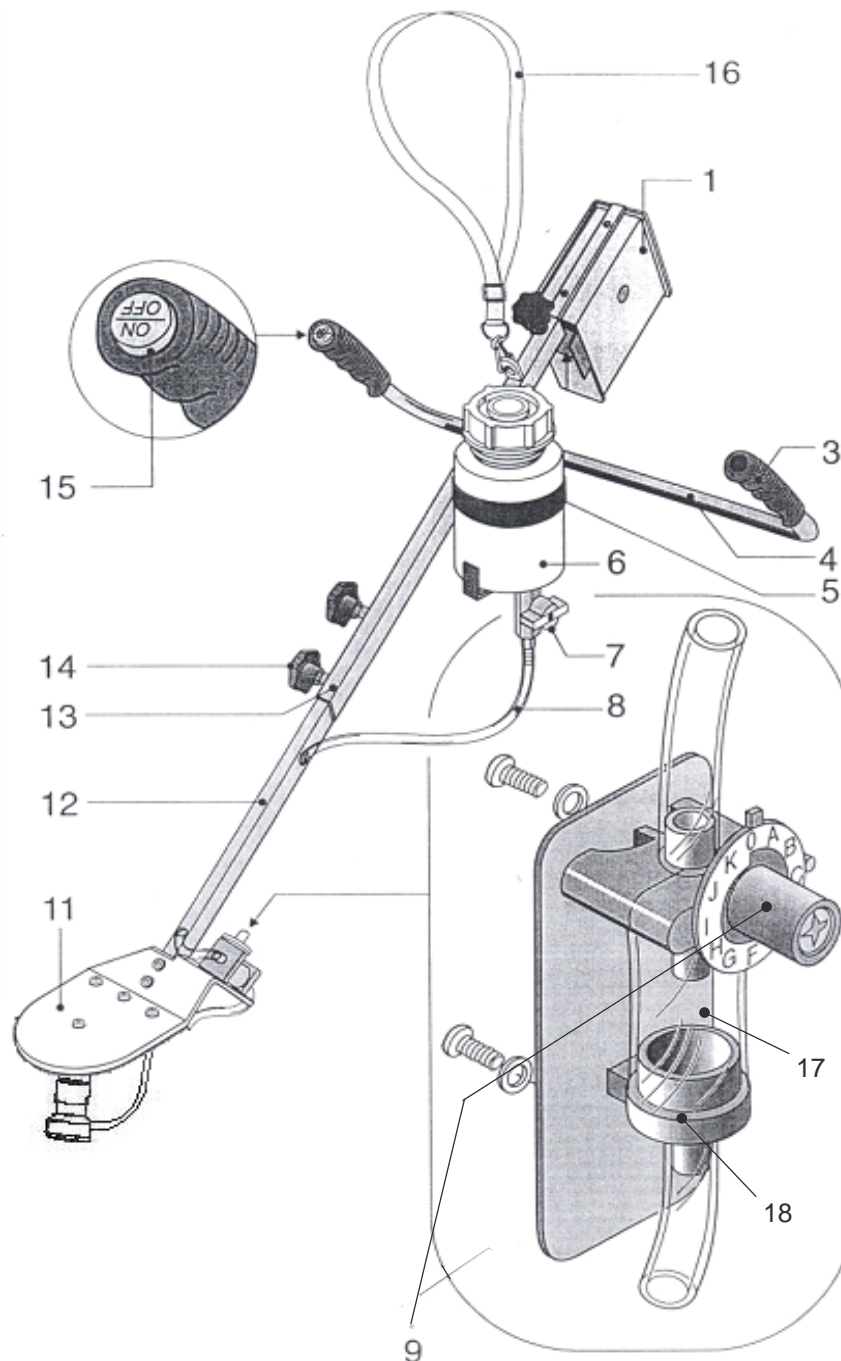

**Item Part No. Description**

**103274 BEMA 1000**

1	100896	Powerpack compl., ABS, 1 battery 12V - 7,2Ah ROFA + BEMA
3	100349	Rubber hand grip for MANKAR
4	100484	Handle bar
5	100367	Tank holder for MANTRA and -110 GP
6	100434	Tank 1 L, MANKAR, without lid
7	100437	Shut-off valve
8	100358	PVC tube 4 x 2 mm, 1200 mm
9	100289	Dosing valve MINI-MANTRA + MANTRA
11	100416	Spray hood bracket
12	100413	Spray hood support
13	100347	Powerpack support
14	100368	Star grip screw, 8 mm x 25
15	100692	Rocker switch
16	100241	Shoulder strap
17	100285	Flow control hose, 16 x 2 mm, 5,5 cm, MANTRA
18	100418	Flow rate controller, lower part, MANKAR, MANTRA

# Components and spare parts

## 100896 Powerpack compl., ABS, 1 battery 12V - 7,2Ah ROFA + BEMA

100469	Powerpack housing
100895	Storage battery 12 V - 7 Ah
100460	Powerpack-cover MINI-MANTRA complete
100730	Fuse T3.15 Amp

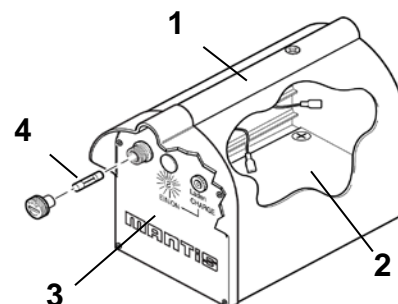

## 100130 Atomiser MAFEX complete, incl. Megi-Shock absorber

100121	Screwed cable gland PG 7, plastic
100388	Atomiser cable, Mankar/Flex/Var/Mafex
100123	Cover, upper part
101977	Motor for ROFA / MAFEX atomiser
100125	Rubber gasket
100126	Cover, lower part
100132	Atomiser disc for MAFEX / ROFA

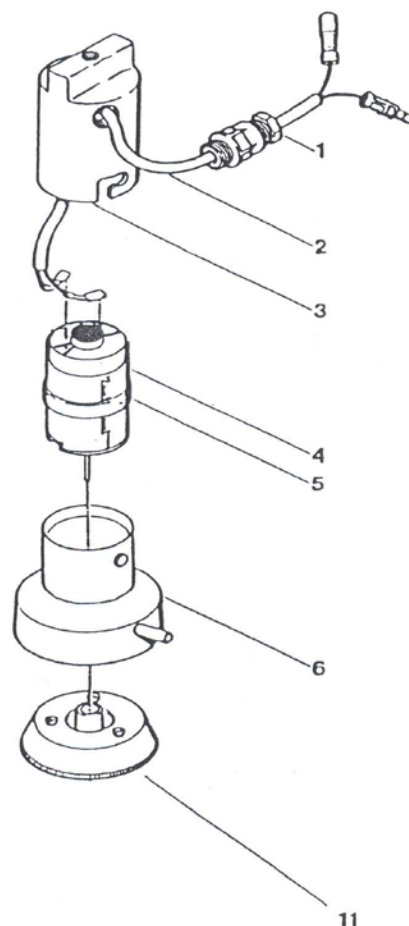

## GUARANTEE

- I. If the purchase is a commercial transaction for both sides, the Customer must examine the goods immediately on receipt, as far as this is possible during the regular course of business and if there is a defect, inform the Vendor immediately.
- II. If the Customer does not make a complaint, the goods are considered approved, unless there is a defect, which was not visible during the examination. Furthermore §§ 377 ff. HGB applies.
- III. The Vendor may choose to eliminate the defects or deliver an item free of defects, (rectification of defects). If the rectification of defects fails, the Customer has the right to choose to either demand a reduction in price or to withdraw from the contract.
- IV. Further claims from the Customer, in particular due to consequential damage caused by a defect are in principle disqualified. This does not apply in cases of intent, gross negligence or breaches of contract by the Vendor as well as in cases of injury to life, body or health. The right of the Customer to withdraw from the contract remains unaffected.
- V. Warranty claims lapse after 24 months, respectively after 12 months in case of commercial use of the goods. The limitation period begins at delivery. The guarantee expires, if the delivered goods change or are handled incorrectly.
- VI. The Vendor is not responsible for material defects on deliveries, which he sources from third parties and forwards unchanged to the Customer. Responsibility in the case of intent or negligence remains unaffected. The preceding regulations do not imply a change to the burden of proof to the disadvantage of the Customer.
- VII. Claims for defects do not only exist in cases of negligible deviations from the agreed properties and conditions or only in negligible impairment of usefulness.
- VIII. Necessary expenses for the purpose of the rectifying defects are to be paid by the Customer, if they increase due to delivery to a different place than the place of business of the Customer, unless the transport corresponds to its intended use.

## **EG-Declaration of conformity Council Directive 2006/42/EG**

Mantis ULV-Sprühgeräte GmbH, Vierlander Straße 11 a, 21502 Geesthacht declares under our sole responsibility that the following products are in conformity with the provisions of the following Council Directive: 2006/42/EG

Typ MANKAR-P, MANKAR-110-P, MANKAR-110-GP, MANKAR-L,  
MANKAR-110 SELECT EL  
Typ MANTRA, MINI-MANTRA / PLUS, MICRO-MANTRA, MICRO-VASO  
Typ FLEXOMANT-1W, FLEXOMANT-2W, FLEXOMANT-3W, FLEXOMANT-4W,  
FLEXOMANT-PLUS, VARIMANT-1, VARIMANT-2, VARIMANT-4 PLUS,  
VARIMANT-WINNER-TOP, VARIMANT-WINNER-UNO  
Typ MAFEX  
Typ ROFA

André Verder  
Managing Director

Geesthacht January 2012

\_\_\_\_\_  
(Place and date of signature)

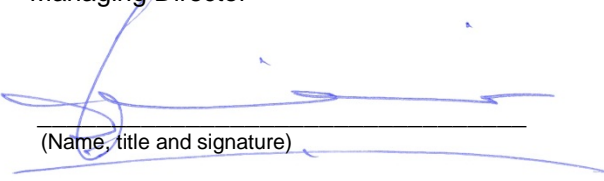
  
\_\_\_\_\_  
(Name, title and signature)